

NSK

LONG-LIFE SEALED SPHERICAL ROLLER BEARINGS

FOR MINING INDUSTRY CONVEYOR PULLEYS



STAY IN MOTION. STAY IN CONTROL.



UNRELENTING GRIT

BEARINGS FOR MINING, QUARRYING & CONSTRUCTION

Punishing Loads. Misalignment. Mechanical shock. Grit and contamination and marginal lubrication. A day in a life for bearings used in mining, quarrying and construction industries.

For the machinery and equipment used to extract, transport and process - interdependent in their purpose - access can be remote or restricted. The unexpected failure of a single component can bring an entire site to a standstill - at a significant cost.

For NSK, product development and design is focused squarely on withstanding the manifold operating and environmental stresses of these applications with:

- › increasing capacities for high loads and high speeds
- › advanced materials for durability, wear resistance and longer life
- › lubrication and seal technology for smooth and clean running

Our product solutions are designed to optimize the performance of machinery and equipment, to assure predictable reliability and to deliver total cost-efficiency.

CONTAMINANT AND WEAR RESISTANT: SEALED SPHERICAL ROLLER BEARINGS

Durability and reliability are paramount to bearings used in mining and quarrying conveyor applications, where failure can impact an entire operation. For the arduous and highly contaminated operating conditions that typically prevail, NSK has developed our spherical roller bearing with removable seal. Combining our long-life Hi-TF material with an easy-to-install seal, NSK has delivered an advanced, reliable contaminant- and wear-resistant solution.

PROVEN BENEFITS

- › NSK Hi-TF long-life steel delivers dramatically longer service life in contaminated operating environments
- › High performance seal design, including characteristics to compensate for bearing misalignment
 - › Removable seal permits measurement of internal clearance during installation
 - › Easy, bolt-fastened installation of seal
 - › Dimensionally interchangeable with conventional spherical roller bearings



DESIGN FEATURES AND OPERATING ADVANTAGES

NSK's Hi-TF spherical roller bearings with removable seal were engineered to deliver substantially longer life in the high-contaminant environments of mines, quarries and construction applications. Long-life Tough Steel™ technology combines with an advanced geometry solid brass cage and innovative removable seal for smooth, clean-running, long-life operation.

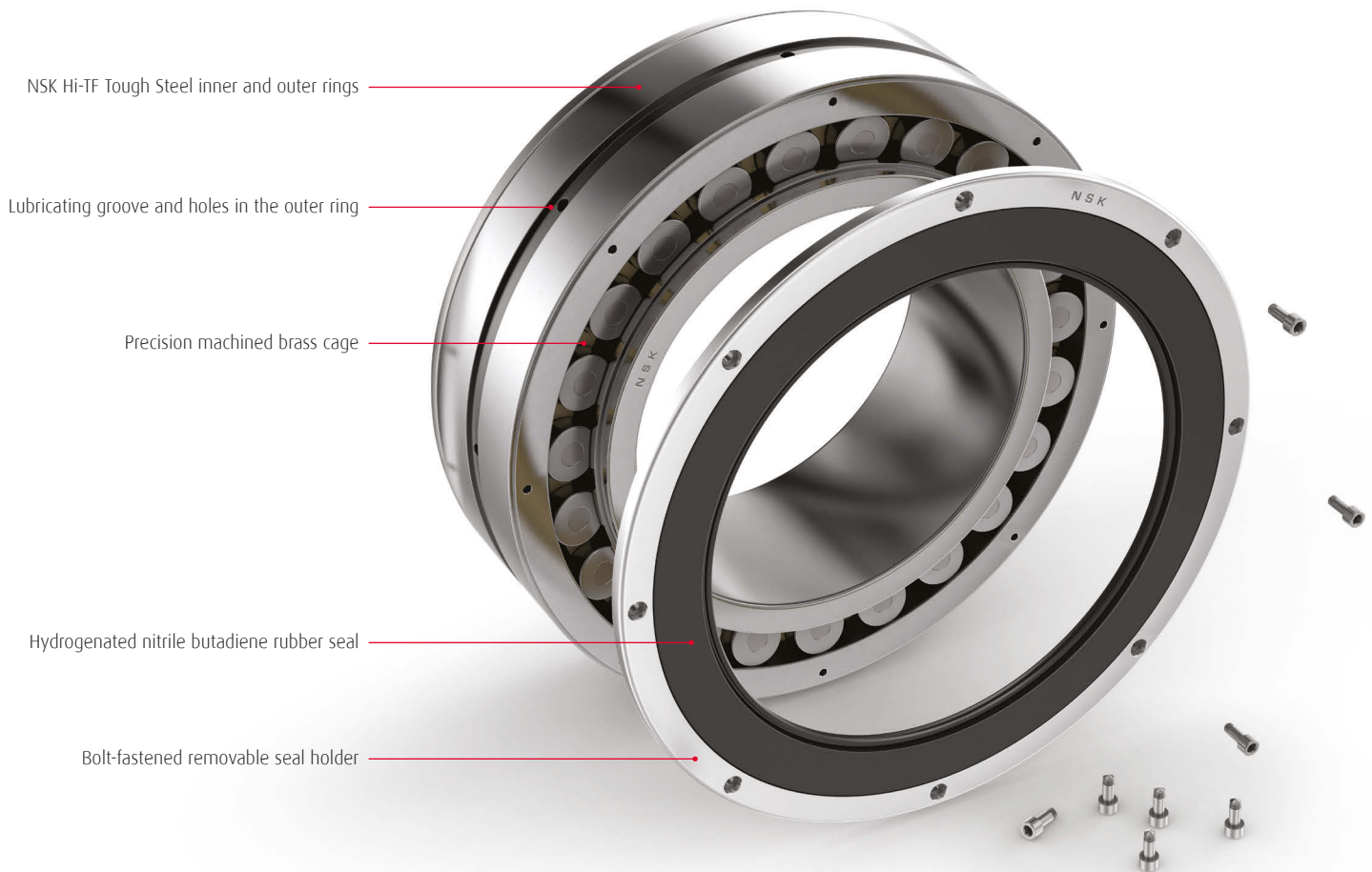

DESIGN FEATURES

- › Special design spherical roller bearing with removable seal
- › Dimensionally interchangeable with standard designs
- › Manufactured with Hi-TF long-life steel
- › Removable seal locates on the bearing inner ring with easy, bolt-fastened installation to bearing outer ring
- › Equipped with a heavy-duty precision machined one-piece brass cage
- › Cage geometry optimizes roller guidance and lubricant distribution to rolling contact surfaces
- › Tapered bore standard - for cylindrical bore, contact NSK
- › With outer ring lubrication groove and holes
- › For spherical roller bearing dimensional series 222 and 231

HIGH PERFORMANCE SEAL DESIGN

NSK's removable seal design offers considerable advantages for efficient and accurate bearing installation, and to provide optimal protection from contaminant ingress:

- › Integral garter spring ensures high sealing performance with ability to compensate for bearing misalignment
- › Seal lip contacts on the bearing inner ring, with easy, bolt-fastened installation of the removable seal holder to the bearing outer ring
- › Hydrogenated nitrile butadiene rubber seal material is suitable for operating temperatures up to 100°C
- › Bearings are supplied without packed grease – selection and fill occurs at the time of installation

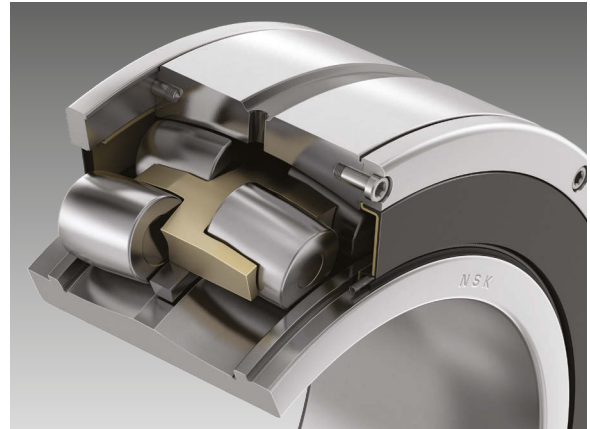

HIGH PERFORMANCE MATERIAL

NSK has adopted our Hi-TF long-life Tough Steel material for bearing inner and outer rings. Utilizing advanced material engineering and heat treatment technology, NSK Hi-TF offers considerable advantages over conventional materials:

- › Exponentially longer service life in contaminated lubrication conditions
- › Reduced rate of wear and improved seizure resistance
- › Organically higher attainable dynamic loads

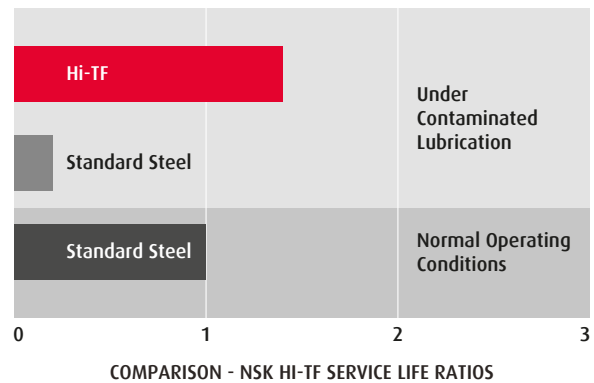

DESIGNATION SYSTEM - AFTERMARKET

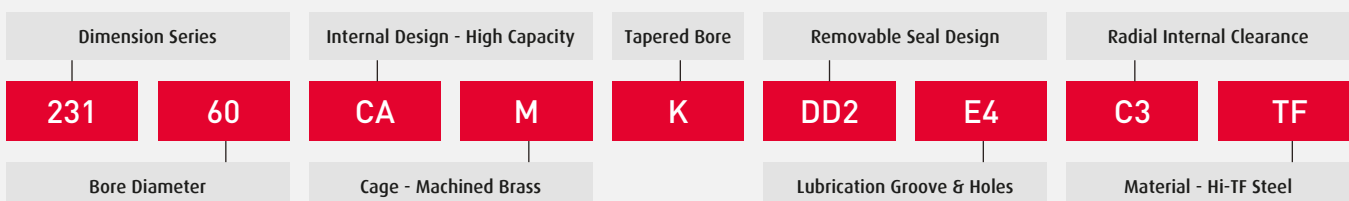

BEARING DIMENSIONS AND OPERATING VALUES

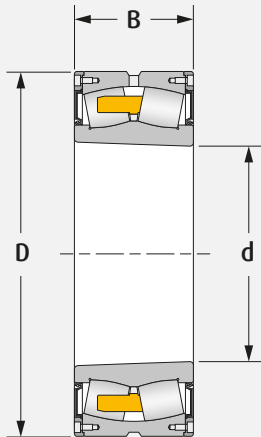

Special spherical roller bearings with removable seal have the same boundary dimensions as standard spherical roller bearings.

No modifications to housings or surrounding structures are required.

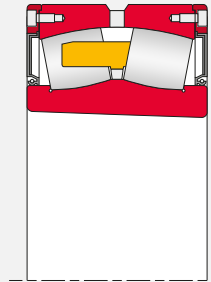

Sealed Spherical Series 231

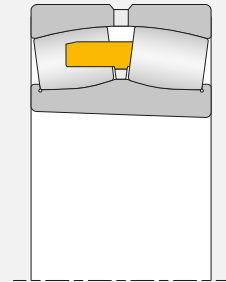

Standard Spherical Series 231

BEARING PART NO. (AFTERMARKET)	BEARING DIMENSIONS			BASIC LOAD RATINGS		LIMITING SPEED	LUBRICATION		
	mm			kN		Grease	Init. Fill	Replenishment	
	d	D	B	Dynamic	Static	rpm	g	hrs	g
22224CAMKDD2E4C3TF	120	215	58	480	525	1 050	80	10 000	19
22226CAMKDD2E4C3TF	130	230	64	565	635	970	100	9 700	22
22228CAMKDD2E4C3TF	140	250	68	680	765	890	130	9 100	26
22230CAMKDD2E4C3TF	150	270	73	780	895	820	160	8 600	30
22232CAMKDD2E4C3TF	160	290	80	900	1 050	780	210	8 200	35
23134CAMKDD2E4C3TF	170	280	88	915	1 230	770	165	7 700	37
23136CAMKDD2E4C3TF	180	300	96	1 060	1 400	720	220	7 400	43
23138CAMKDD2E4C3TF	190	320	104	1 190	1 540	670	340	7 000	50
23140CAMKDD2E4C3TF	200	340	112	1 360	1 790	630	390	6 700	57
23144CAMKDD2E4C3TF	220	370	120	1 570	2 140	580	480	6 100	67
23148CAMKDD2E4C3TF	240	400	128	1 830	2 470	540	650	5 700	77
23152CAMKDD2E4C3TF	260	440	144	2 210	2 980	490	850	5 200	95
23156CAMKDD2E4C3TF	280	460	146	2 330	3 300	460	850	4 900	100
23160CAMKDD2E4C3TF	300	500	160	2 770	4 000	430	1 100	4 500	120
23164CAMKDD2E4C3TF	320	540	176	3 400	4 850	400	1 450	4 200	140
23168CAMKDD2E4C3TF	340	580	190	3 850	5 450	370	1 800	4 000	170
23172CAMKDD2E4C3TF	360	600	192	3 900	5 600	360	2 400	3 700	170
23176CAMKDD2E4C3TF	380	620	194	4 000	5 850	350	2 600	3 500	180
23180CAMKDD2E4C3TF	400	650	200	4 200	6 300	330	2 850	3 300	200
23184CAMKDD2E4C3TF	420	700	224	5 250	7 700	310	3 900	3 100	240
23188CAMKDD2E4C3TF	440	720	226	5 450	8 200	300	4 000	2 900	240
23192CAMKDD2E4C3TF	460	760	240	6 050	9 150	280	4 600	2 700	270
23196CAMKDD2E4C3TF	480	790	248	6 550	10 100	270	5 050	2 600	290



IMPROVEMENT PAYS

END-TO-END SERVICE DELIVERS CUSTOMER SUCCESS

Improvement never ends. And we never stop looking for better ways to support our customers in a complete, collaborative and continuous way. The focus of NSK isn't simply on a quick fix for immediate gain – it's about incremental and sustainable improvement to deliver long-term benefits.

When NSK is on-site, we're there to understand our customers' challenges and identify problems contributing to frequent bearing replacement, breakdowns caused by poor specification, high energy costs from inefficient product selection and lost production because of downtime. We collaborate with our customers to institute an **Asset Improvement Program (AIP)** that encompasses process and maintenance management, diagnostic and educational support to deliver measurable gains in output and cost-efficiency.

With NSK, our customers embark on a critical path to realizing improvements in equipment, productivity, people and financial performance.





NSK AMERICAS

United States
NSK Corporation
Ann Arbor MI
1.888.446.5675

Canada
NSK Canada Inc.
Brampton ON
1.888.603.7667

Mexico
NSK Rodamientos Mexicana,
S.A. de C.V.
Silao Guanajuato MX
52.472.500.9500

Brazil
NSK Brasil Ltda.
Suzano SP
55.11.4744.2500

Argentina
NSK Argentina SRL
Buenos Aires
54.11.4704.5100

Latin America
NSK Latin America Inc.
Miramar FL
1.305.477.0605

Website:
www.nskamericas.com
NSK Global: www.nsk.com

Every care has been taken to ensure the accuracy of the data contained in this brochure, but no liability can be accepted for any loss or damage suffered through errors or omissions.

Printed in the USA ©NSK 2024.
The contents of the publication are the copyright of the publishers.